

90CM BUILT-IN ELECTRIC OVEN

MODEL CAO900 X1/B/W



24 MONTH WARRANTY



90CM



98L OVEN CAPACITY



COOKING FUNCTIONS



SHELF POSITIONS



TRIPLE GLAZING



BELL TIMER



HALOGEN GLOBE



15AMP POWER CONNECTION



PRODUCT INFORMATION

FINISH

- Available in AS430 Stainless Steel (X1), Black Glass (B) or White Glass (W)

FEATURES

- 120-minute bell timer
- knob controls
- flat, easy-clean oven door
- removable shelves
- cooling system
- turbo heating

CAPACITY & INTERIOR

- 98 litres gross
- 5 cooking levels
- EVER-Clean enamel oven cavity
- Oven cavity size: 64.5W x 33H x 41Dcm usable cavity space

SAFETY

- triple-glazed glass door

FUNCTIONS

- 9 functions- light, defrost, grill, fan forced, bottom, convection, fan assisted, half fan grill, fan grill

ACCESSORIES

- 1 x oven rack
- 1 x baking dish with grill insert
- 1 x heat resistant handle
- 1 x telescopic rack with 75% extraction

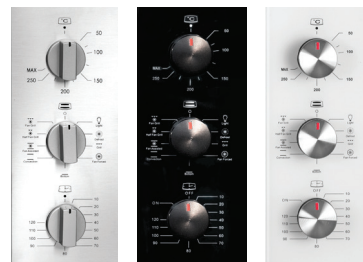

AR22032022

DISCLAIMER

Eurolinx PTY LTD, is continually seeking ways to improve the design specifications, aesthetics and production techniques of its products. As a result alterations to our products and designs take place continually. Whilst every effort is made to produce information and literature that is up to date, this brochure should not be regarded as an infallible guide to the current specifications, nor does it constitute an offer for the sale of any particular product. Product dimensions indicated in our literature is indicative only. Actual product only should be used to define dimension cut outs. Distributors, and retailers are not agents of Eurolinx and are not authorized to bind Eurolinx by any express or implied undertaking or representation.

FOLLOW US ON:  [instagram.com/artusi_appliances](https://www.instagram.com/artusi_appliances)

 www.linkedin.com/company/eurolinx-pty-ltd-t-a-lv/

Australia National Telephone Number 1300 (694 583) New Zealand Telephone Number 64 3 344 5913
Artusi showroom hours: Tuesday to Friday - 9am-5pm, Saturday - 10am-4pm, Sunday and Monday - closed
* Melbourne showroom hours: Tuesday to Saturday - 10am-4pm

[artusi.com.au](https://www.artusi.com.au)

NSW & ACT (Head Office)
48-50 Moore Street
Leichhardt
F 02 8569 4699

QLD
1/42 Cavendish Road
Coorparoo
F 07 3397 0850

WA & NT
Unit 10/55 Howe Street
Osborne Park
F 08 9201 9188

New Zealand
PO Box 11,160
Sockburn Christchurch
F 03 344 5906

90CM BUILT-IN ELECTRIC OVEN

MODEL CAO900 X1/B/W

TECHNICAL DIAGRAM

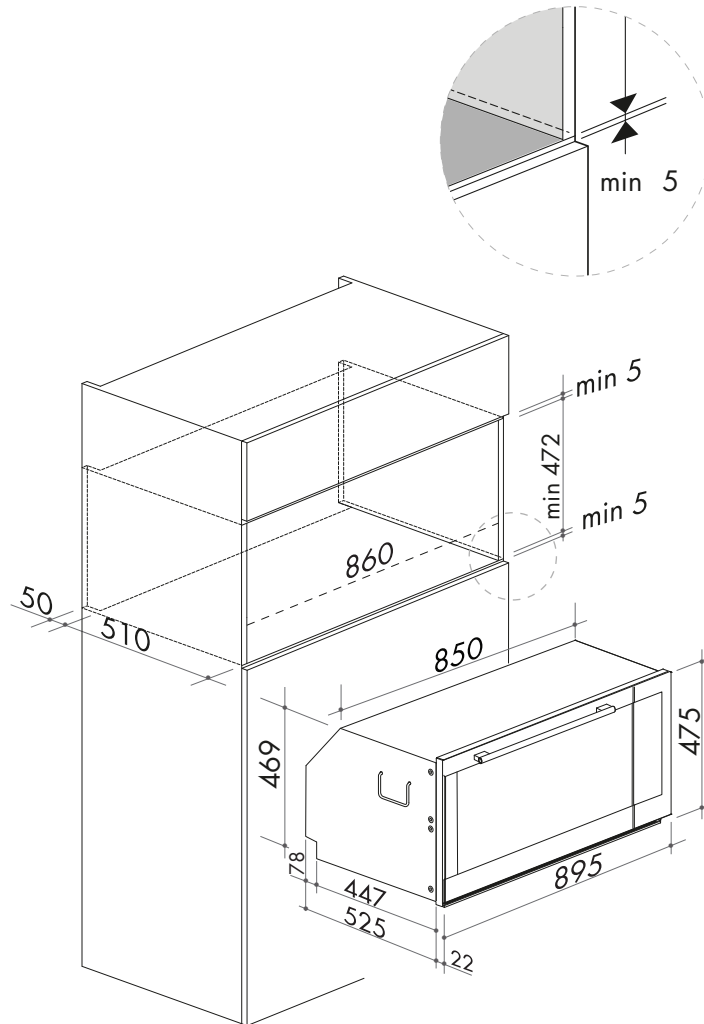

NB: drawings are not to scale — they are to be used for detailed installation instructions, please refer to user guide.

CAO900X1 EAN 9347777001344
CAO900B EAN 9347777003683
CAO900W EAN 9347777004864

AR22032022

DISCLAIMER

Eurolinx PTY LTD, is continually seeking ways to improve the design specifications, aesthetics and production techniques of its products. As a result alterations to our products and designs take place continually. Whilst every effort is made to produce information and literature that is up to date, this brochure should not be regarded as an infallible guide to the current specifications, nor does it constitute an offer for the sale of any particular product. Product dimensions indicated in our literature is indicative only. Actual product only should be used to define dimension cut outs. Distributors, and retailers are not agents of Eurolinx and are not authorized to bind Eurolinx by any express or implied undertaking or representation.

CAO900 Electric Built-in Oven
3.5kW/hr total electrical consumption
15 amp electrical connection, hard wired
1.2m power cord length
40.5kg net, 46kg gross

FOLLOW US ON:  [instagram.com/artusi_appliances](https://www.instagram.com/artusi_appliances)

 www.linkedin.com/company/eurolinx-pty-ltd-t-a-ilve/

Australia National Telephone Number 1300 (694 583) New Zealand Telephone Number 64 3 344 5913
Artusi showroom hours: Tuesday to Friday - 9am-5pm, Saturday - 10am-4pm, Sunday and Monday - closed
* Melbourne showroom hours: Tuesday to Saturday - 10am-4pm

[artusi.com.au](https://www.artusi.com.au)

NSW & ACT (Head Office)
48-50 Moore Street
Leichhardt
F 02 8569 4699

QLD
1/42 Cavendish Road
Coorparoo
F 07 3397 0850

WA & NT
Unit 10/55 Howe Street
Osborne Park
F 08 9201 9188

New Zealand
PO Box 11.160
Sockburn Christchurch
F 03 344 5906