

# 60CM BUILT-IN COMBI-MICROWAVE

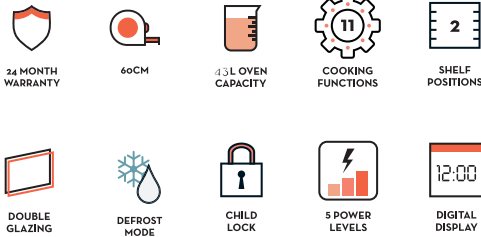

MODEL CAMC45B



## PRODUCT INFORMATION

### FINISH

- Black Glass with stainless steel handle

### FEATURES

- Digital Touch control
- LED display
- push down control knobs
- cooling fan
- rapid pre-heating\*
- 900W microwave
- 5 microwave power settings
- 1750W Top Grill
- 1750W Convection
- Max. Power: 3350W

### CAPACITY & INTERIOR

- 44L cavity size
- stainless steel cavity
- Internal cavity size (cm): 42W x 42D x 25H
- 2 shelf positions

### FUNCTIONS

- 13 automatic programs
- 11 combined cooking functions: fan forced (3D hot air), grill with fan, pizza, grill, microwave + fan forced, microwave + fan grill, microwave + pizza, microwave + grill, defrost, auto programs, microwave

### SAFETY

- Child safety lock
- double glazed glass door

### ACCESSORIES

- 1 x Wire rack
- Ø360mm enamelled turntable
- 2 x grill racks
- 1 x glass tray



EAN 9347777004031

AR27052022

### DISCLAIMER

Eurolinx PTY LTD, is continually seeking ways to improve the design specifications, aesthetics and production techniques of its products. As a result alterations to our products and designs take place continually. Whilst every effort is made to produce information and literature that is up to date, this brochure should not be regarded as an infallible guide to the current specifications, nor does it constitute an offer for the sale of any particular product. Product dimensions indicated in our literature is indicative only. Actual product only should be used to define dimension cut outs. Distributors, and retailers are not agents of Eurolinx and are not authorized to bind Eurolinx by any express or implied undertaking or representation.

FOLLOW US ON: [instagram.com/artusi\\_appliances](https://www.instagram.com/artusi_appliances)

[www.linkedin.com/company/eurolinx-pty-ltd-t-a-llve/](https://www.linkedin.com/company/eurolinx-pty-ltd-t-a-llve/)

Australia National Telephone Number 1300 (694 583) New Zealand Telephone Number 64 3 344 5913  
Artusi showroom hours: Tuesday to Friday - 9am-5pm, Saturday - 10am-4pm, Sunday and Monday - closed  
\* Melbourne showroom hours: Tuesday to Saturday - 10am-4pm

[artusi.com.au](https://www.artusi.com.au)

NSW & ACT (Head Office)  
48-50 Moore Street  
Leichhardt  
F 02 8569 4699

QLD  
1/42 Cavendish Road  
Coorparoo  
F 07 3397 0850

WA & NT  
Unit 10/55 Howe Street  
Osborne Park  
F 08 9201 9188

New Zealand  
PO Box 11,160  
Sockburn Christchurch  
F 03 344 5906

**MODEL** CAMC45B

## TECHNICAL DIAGRAM

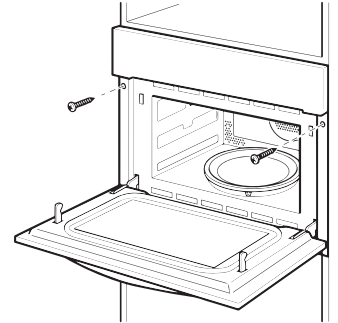
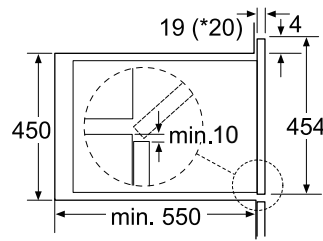
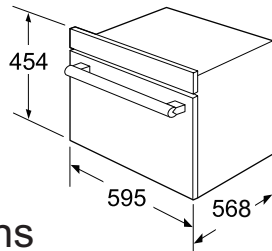

### Installation dimensions

\* 20 mm for metal fascias

Ventilation openings  
behind, min. 250 cm<sup>2</sup>

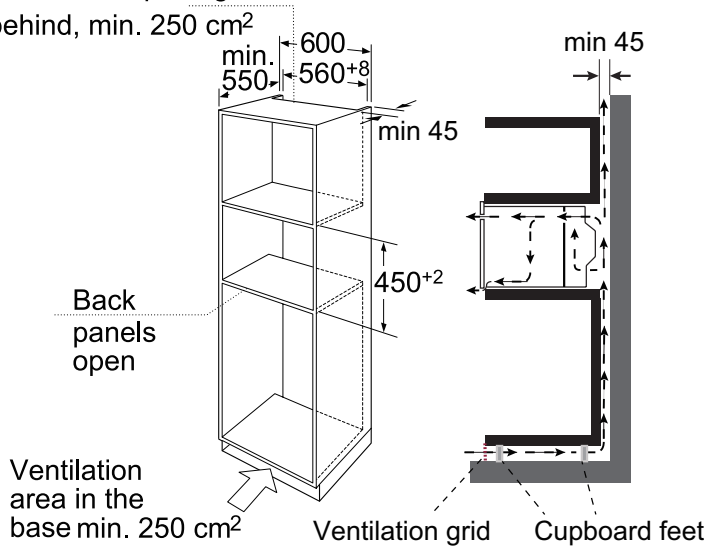

Note: There should be gap above the oven.

NB: drawings are not to scale — they are to be used for detailed installation instructions, please refer to user guide.

**EAN 9347777004031**

AR27052022

### DISCLAIMER

Eurolinx PTY LTD, is continually seeking ways to improve the design specifications, aesthetics and production techniques of its products. As a result alterations to our products and designs take place continually. Whilst every effort is made to produce information and literature that is up to date, this brochure should not be regarded as an infallible guide to the current specifications, nor does it constitute an offer for the sale of any particular product. Product dimensions indicated in our literature is indicative only. Actual product only should be used to define dimension cut outs. Distributors, and retailers are not agents of Eurolinx and are not authorized to bind Eurolinx by any express or implied undertaking or representation.

CAMC45B Built-in Combi-Microwave  
Unit Size: W595\*H455\*D525mm  
140cm power cord

**FOLLOW US ON:** [instagram.com/artusi\\_appliances](https://www.instagram.com/artusi_appliances)

[www.linkedin.com/company/eurolinx-pty-ltd-t-a-lve/](https://www.linkedin.com/company/eurolinx-pty-ltd-t-a-lve/)

Australia National Telephone Number 1300 (694 583) New Zealand Telephone Number 64 3 344 5913  
Artusi showroom hours: Tuesday to Friday - 9am-5pm, Saturday - 10am-4pm, Sunday and Monday - closed  
\* Melbourne showroom hours: Tuesday to Saturday - 10am-4pm

[artusi.com.au](https://www.artusi.com.au)

**NSW & ACT (Head Office)**  
48-50 Moore Street  
Leichhardt  
F 02 8569 4699

**QLD**  
1/42 Cavendish Road  
Coorparoo  
F 07 3397 0850

**WA & NT**  
Unit 10/55 Howe Street  
Osborne Park  
F 08 9201 9188

**New Zealand**  
PO Box 11,160  
Sockburn Christchurch  
F 03 344 5906