

FREESTANDING MICROWAVE

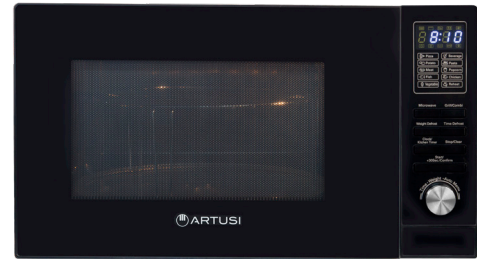

MODEL AMG25B

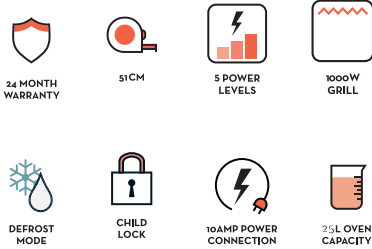

PRODUCT INFORMATION

FINISH

- Black glass

FEATURES

- 900W microwave power
- 1000W Grill power
- 5 Power levels: 10%, 30%, 50%, 80%, 100%
- quick start button
- clock and timer
- push-open door

CAPACITY & INTERIOR

- 25L cavity size
- cavity dimensions: 35.5W x 20.5H x 35Dcm
- painted cavity

SAFETY

- child safety lock

FUNCTIONS

- 10 Auto cooking menus: pizza, potato, meat, fish, vegetables, beverage, pasta, popcorn, chicken, reheat
- grill/combination cooking
- multi-section cooking
- defrost by time
- defrost by weight

ACCESSORIES

- turntable
- grill insert

DISCLAIMER

Eurolinx PTY LTD, is continually seeking ways to improve the design specifications, aesthetics and production techniques of its products. As a result alterations to our products and designs take place continually. Whilst every effort is made to produce information and literature that is up to date, this brochure should not be regarded as an infallible guide to the current specifications, nor does it constitute an offer for the sale of any particular product. Product dimensions indicated in our literature is indicative only. Actual product only should be used to define dimension cut outs. Distributors, and retailers are not agents of Eurolinx and are not authorized to bind Eurolinx by any express or implied undertaking or representation.



EAN 9347777003645

AR09042021

FOLLOW US ON: [instagram.com/artusi_appliances](https://www.instagram.com/artusi_appliances)

www.linkedin.com/company/eurolinx-pty-ltd-t-a-lve/

Australia National Telephone Number 1300 (694 583) New Zealand Telephone Number 64 3 344 5913
Artusi showroom hours: Tuesday to Friday - 9am-5pm, Saturday - 10am-4pm, Sunday and Monday - closed
* Melbourne showroom hours: Tuesday to Saturday - 10am-4pm

[artusi.com.au](https://www.artusi.com.au)

NSW & ACT (Head Office)
48-50 Moore Street
Leichhardt
F 02 8569 4699

QLD
1/42 Cavendish Road
Coorparoo
F 07 3397 0850

WA & NT
Unit 10/55 Howe Street
Osborne Park
F 08 9201 9188

New Zealand
PO Box 11,160
Sockburn Christchurch
F 03 344 5906

FREESTANDING MICROWAVE

MODEL AMG25B

TECHNICAL DIAGRAM

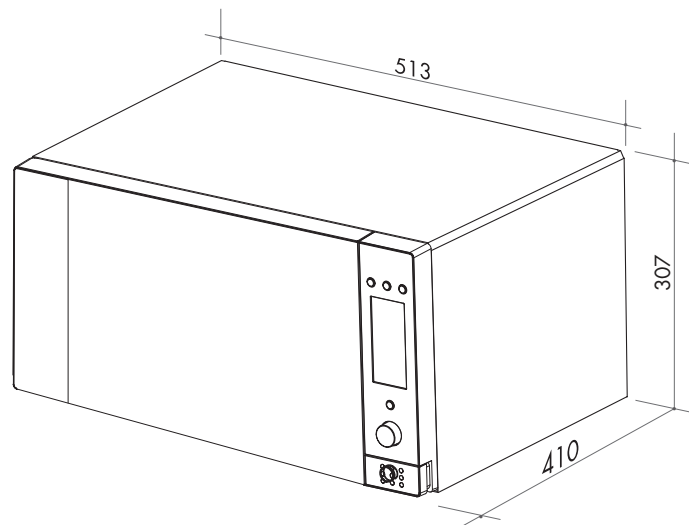

NB: drawings are not to scale — they are to be used for detailed installation instructions, please refer to user guide.

EAN 9347777003645

AR08042021

DISCLAIMER

Eurolinx PTY LTD, is continually seeking ways to improve the design specifications, aesthetics and production techniques of its products. As a result alterations to our products and designs take place continually. Whilst every effort is made to produce information and literature that is up to date, this brochure should not be regarded as an infallible guide to the current specifications, nor does it constitute an offer for the sale of any particular product. Product dimensions indicated in our literature is indicative only. Actual product only should be used to define dimension cut outs. Distributors, and retailers are not agents of Eurolinx and are not authorized to bind Eurolinx by any express or implied undertaking or representation.

AMG25B Black Glass Freestanding Microwave
513W X 410D X 307H mm
10 AMP, 3-pin plug and cord
1m power cord

FOLLOW US ON:  [instagram.com/artusi_appliances](https://www.instagram.com/artusi_appliances)

 www.linkedin.com/company/eurolinx-pty-ltd-t-a-lve/

Australia National Telephone Number 1300 (694 583) New Zealand Telephone Number 64 3 344 5913
Artusi showroom hours: Tuesday to Friday - 9am-5pm, Saturday - 10am-4pm, Sunday and Monday - closed
*** Melbourne showroom hours:** Tuesday to Saturday - 10am-4pm

[artusi.com.au](https://www.artusi.com.au)

NSW & ACT (Head Office)
48-50 Moore Street
Leichhardt
F 02 8569 4699

QLD
1/42 Cavendish Road
Coorparoo
F 07 3397 0850

WA & NT
Unit 10/55 Howe Street
Osborne Park
F 08 9201 9188

New Zealand
PO Box 11,160
Sockburn Christchurch
F 03 344 5906