

FULLY INTEGRATED BAR FRIDGE

ARTUSI
THE ART OF LIVING

MODEL AINT119/NF2



24 MONTH WARRANTY



60CM



135L FRIDGE CAPACITY



SHELF POSITIONS



LED LIGHTS



DEFROST MODE



LOW NOISE



10AMP POWER CONNECTION



*integrated door panel not supplied

PRODUCT INFORMATION

FINISH

- white interior

FEATURES

- 12 hour storage in the event of power failure
- auto defrost
- Static vented cooling system
- 1 - 5 temperature selection range
- Current (A) <10
- A+ Energy rating
- Single compressor
- Automatic fridge defrost
- power LED cavity light
- Noise: 40db/A

DOOR

- Supplied with right hand hinge (reversible)
- fixed hinge door system

CAPACITY & INTERIOR

- 135L net capacity
- 2 x adjustable glass shelves & 1 x split shelf with direct access to crispers
- 2x Crystal clear door shelves
- 2x crispers

TEMPERATURE

- 5 cooling levels

ACCESSORIES

- 1x transparent egg tray

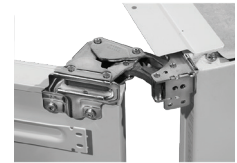

EAN 9347777004727

AR05042022

DISCLAIMER

Eurolinx PTY LTD, is continually seeking ways to improve the design specifications, aesthetics and production techniques of its products. As a result alterations to our products and designs take place continually. Whilst every effort is made to produce information and literature that is up to date, this brochure should not be regarded as an infallible guide to the current specifications, nor does it constitute an offer for the sale of any particular product. Product dimensions indicated in our literature is indicative only. Actual product only should be used to define dimension cut outs. Distributors, and retailers are not agents of Eurolinx and are not authorized to bind Eurolinx by any express or implied undertaking or representation.

FOLLOW US ON: [instagram.com/artusi_appliances](https://www.instagram.com/artusi_appliances)

www.linkedin.com/company/eurolinx-pty-ltd-t-a-lve/

Australia National Telephone Number 1300 (694 583) New Zealand Telephone Number 64 3 344 5913
Artusi showroom hours: Tuesday to Friday - 9am-5pm, Saturday - 10am-4pm, Sunday and Monday - closed
* Melbourne showroom hours: Tuesday to Saturday - 10am-4pm

[artusi.com.au](https://www.artusi.com.au)

NSW & ACT (Head Office)
48-50 Moore Street
Leichhardt
F 02 8569 4699

QLD
1/42 Cavendish Road
Coorparoo
F 07 3397 0850

WA & NT
Unit 10/55 Howe Street
Osborne Park
F 08 9201 9188

New Zealand
PO Box 11,160
Sockburn Christchurch
F 03 344 5906

FULLY INTEGRATED BAR FRIDGE



MODEL AINT119/NF2

TECHNICAL DIAGRAM

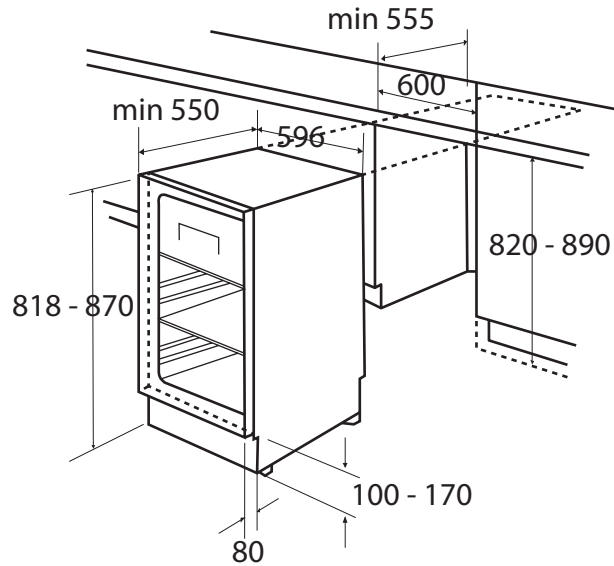

Installation kit

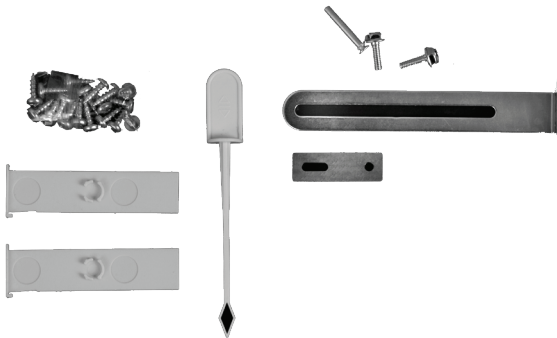

For custom kick panels, a grille with a minimum aperture of 0.2m² is required

NB: drawings are not to scale — they are to be used for detailed installation instructions, please refer to user guide.

EAN 9347777004727

AR05042022

DISCLAIMER

Eurolinx PTY LTD, is continually seeking ways to improve the design specifications, aesthetics and production techniques of its products. As a result alterations to our products and designs take place continually. Whilst every effort is made to produce information and literature that is up to date, this brochure should not be regarded as an infallible guide to the current specifications, nor does it constitute an offer for the sale of any particular product. Product dimensions indicated in our literature is indicative only. Actual product only should be used to define dimension cut outs. Distributors, and retailers are not agents of Eurolinx and are not authorized to bind Eurolinx by any express or implied undertaking or representation.

AINT119/NF2 Fully Integrated Bar Fridge
Total annual energy consumption 302 (kWh)
Voltage (V) 220-240
10 AMP plug and cord
160cm power cord length

FOLLOW US ON: [instagram.com/artusi_appliances](https://www.instagram.com/artusi_appliances)

www.linkedin.com/company/eurolinx-pty-ltd-t-a-lve/

Australia National Telephone Number 1300 (694 583) New Zealand Telephone Number 64 3 344 5913
Artusi showroom hours: Tuesday to Friday - 9am-5pm, Saturday - 10am-4pm, Sunday and Monday - closed
* Melbourne showroom hours: Tuesday to Saturday - 10am-4pm

[artusi.com.au](https://www.artusi.com.au)

NSW & ACT (Head Office)
48-50 Moore Street
Leichhardt
F 02 8569 4699

QLD
1/42 Cavendish Road
Coorparoo
F 07 3397 0850

WA & NT
Unit 10/55 Howe Street
Osborne Park
F 08 9201 9188

New Zealand
PO Box 11,160
Sockburn Christchurch
F 03 344 5906