

MODEL ACM45X



60CM BUILT-IN COMBI-MICROWAVE



MADE
IN ITALY



24 MONTH
WARRANTY



60CM



DOUBLE
GLAZING

PRODUCT INFORMATION

- 10 combined functions
- automatic cooking
- pre-selected and customisable recipes (weight, temperature, cooking time)
- microwave mode (6 levels) combined
- microwave and fan assisted mode
- combined cooking mode
- microwave and grill mode
- defrosting by time and weight
- control panel with touch controls
- stainless steel interior
- internal lighting
- internal capacity 34 litres
- door with safety lock
- door contact switch
- control panel safety function
- tangential cooling ventilation

STANDARD ACCESSORIES

- 1 round grill rack
- 1 stainless steel tray with grill support
- 1 glass turntable

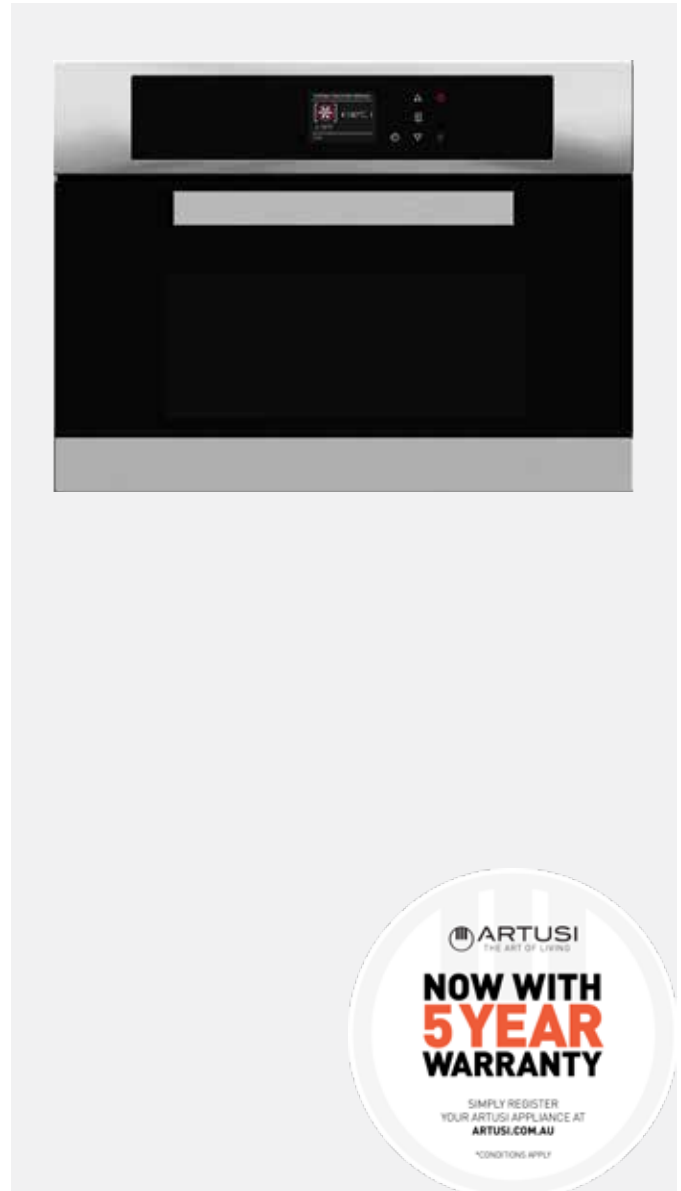

EAN 9347777001825

AR220119

DISCLAIMER

Eurolinx PTY LTD, is continually seeking ways to improve the design specifications, aesthetics and production techniques of its products. As a result alterations to our products and designs take place continually. Whilst every effort is made to produce information and literature that is up to date, this brochure should not be regarded as an infallible guide to the current specifications, nor does it constitute an offer for the sale of any particular product. Product dimensions indicated in our literature is indicative only. Actual product only should be used to define dimension cut outs. Distributors, and retailers are not agents of Eurolinx and are not authorized to bind Eurolinx by any express or implied undertaking or representation.

FOLLOW US ON:  [instagram.com/artusi_appliances](https://www.instagram.com/artusi_appliances)

 www.linkedin.com/company/eurolinx-pty-ltd-t-a-lve/

Australia National Telephone Number 1300 (694 583) New Zealand Telephone Number 64 3 344 5913
 Artusi showroom hours: Tuesday to Friday - 9am-5pm, Saturday - 10am-4pm, Sunday and Monday - closed
 * Melbourne showroom hours: Tuesday to Saturday - 10am-4pm

artusi.com.au

NSW & ACT (Head Office)
 48-50 Moore Street
 Leichhardt
 F 02 8569 4699

VIC & SA
 1211 Toorak Road
 Camberwell
 F 03 9809 2155

QLD
 1/42 Cavendish Road
 Coorparoo
 F 07 3397 0850

WA & NT
 Unit 10/55 Howe Street
 Osborne Park
 F 08 9201 9188

TAS
 3 Pear Avenue
 Derwent Park
 F 03 6272 7386

New Zealand
 PO Box 11,160
 Sockburn Christchurch
 F 03 344 5906

MODEL ACM45X



60CM BUILT-IN COMBI-MICROWAVE

MADE
IN ITALY24 MONTH
WARRANTY

60CM

DOUBLE
GLAZING

TECHNICAL DIAGRAM

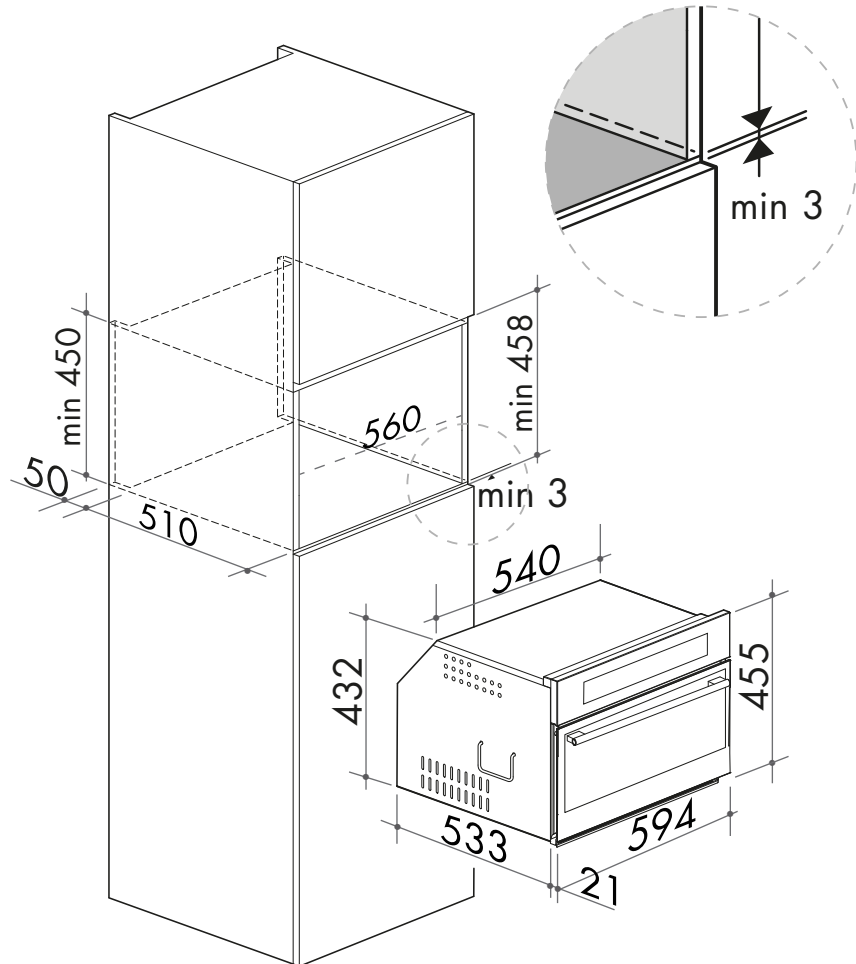

NB: drawings are not to scale — they are to be used for detailed installation instructions, please refer to user guide.

EAN 9347777001825

AR220119

ACM45X Built-in Combi-Microwave

Power requirement: Confirm with Artusi

DISCLAIMER

Eurolinx PTY LTD, is continually seeking ways to improve the design specifications, aesthetics and production techniques of its products. As a result alterations to our products and designs take place continually. Whilst every effort is made to produce information and literature that is up to date, this brochure should not be regarded as an infallible guide to the current specifications, nor does it constitute an offer for the sale of any particular product. Product dimensions indicated in our literature is indicative only. Actual product only should be used to define dimension cut outs. Distributors, and retailers are not agents of Eurolinx and are not authorized to bind Eurolinx by any express or implied undertaking or representation.

FOLLOW US ON:  [instagram.com/artusi_appliances](https://www.instagram.com/artusi_appliances)

 www.linkedin.com/company/eurolinx-pty-ltd-t-a-ilve/

Australia National Telephone Number 1300 (694 583) New Zealand Telephone Number 64 3 344 5913
 Artusi showroom hours: Tuesday to Friday - 9am-5pm, Saturday - 10am-4pm, Sunday and Monday - closed
 * Melbourne showroom hours: Tuesday to Saturday - 10am-4pm

[artusi.com.au](https://www.artusi.com.au)

NSW & ACT (Head Office)
 48-50 Moore Street
 Leichhardt
 F 02 8569 4699

VIC & SA
 1211 Toorak Road
 Camberwell
 F 03 9809 2155

QLD
 1/42 Cavendish Road
 Coorparoo
 F 07 3397 0850

WA & NT
 Unit 10/55 Howe Street
 Osborne Park
 F 08 9201 9188

TAS
 3 Pear Avenue
 Derwent Park
 F 03 6272 7386

New Zealand
 PO Box 11,160
 Sockburn Christchurch
 F 03 344 5906