

AFG940X

90cm freestanding gas/electric cooker

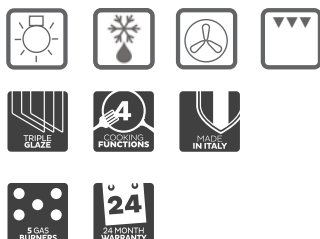

106 litre
USABLE
COOKING
SPACE

SIZE mm 900Wx600Dx885-925H
FINISH stainless steel
CAPACITY 106 litres

OVEN

FEATURES

- 4 functions
- stop-cook timer
- triple-glazed glass door
- fan forced
- electric grill
- oven light
- removable oven cavity floor
- 3 cooking levels
- baking tray
- adjustable legs

HOB

- 5-burner gas hob —
- 1 triple ring 3.8 kW/hr
 - 1 rapid burner 3.0 kW/hr
 - 2 semi-rapid 1.8 kW/hr
 - 1 auxiliary 1.0 kW/hr
- cast-iron trivets and burner caps

POWER

total gas consumption: 11.4 kW/hr
total electrical consumption: 3.6 kW/h
electrical connection: 15AMP
hard connection
220-240V, 50/60Hz
single or three-phase



ARTUSI
THE ART OF COOKING
2 YEARS
PARTS & LABOUR
WARRANTY

EAN 9347777000811

DISCLAIMER

Eurolinx Pty Ltd, trading as ARTUSI Appliances, is continually seeking ways to improve the design specifications, aesthetics and production techniques of its products. As a result alterations to our products and designs take place continually. Whilst every effort is made to produce information and literature that is up to date, this brochure should not be regarded as an infallible guide to the current specifications, nor does it constitute an offer for the sale of any particular product. Product dimensions indicated in our literature is indicative only. Actual product only should be used to define dimension cutouts. Distributors, and retailers are not agents of ARTUSI Appliances and are not authorized to bind ARTUSI Appliances by any express or implied undertaking or representation.

AR200715

AFG940X

90cm freestanding gas/electric cooker

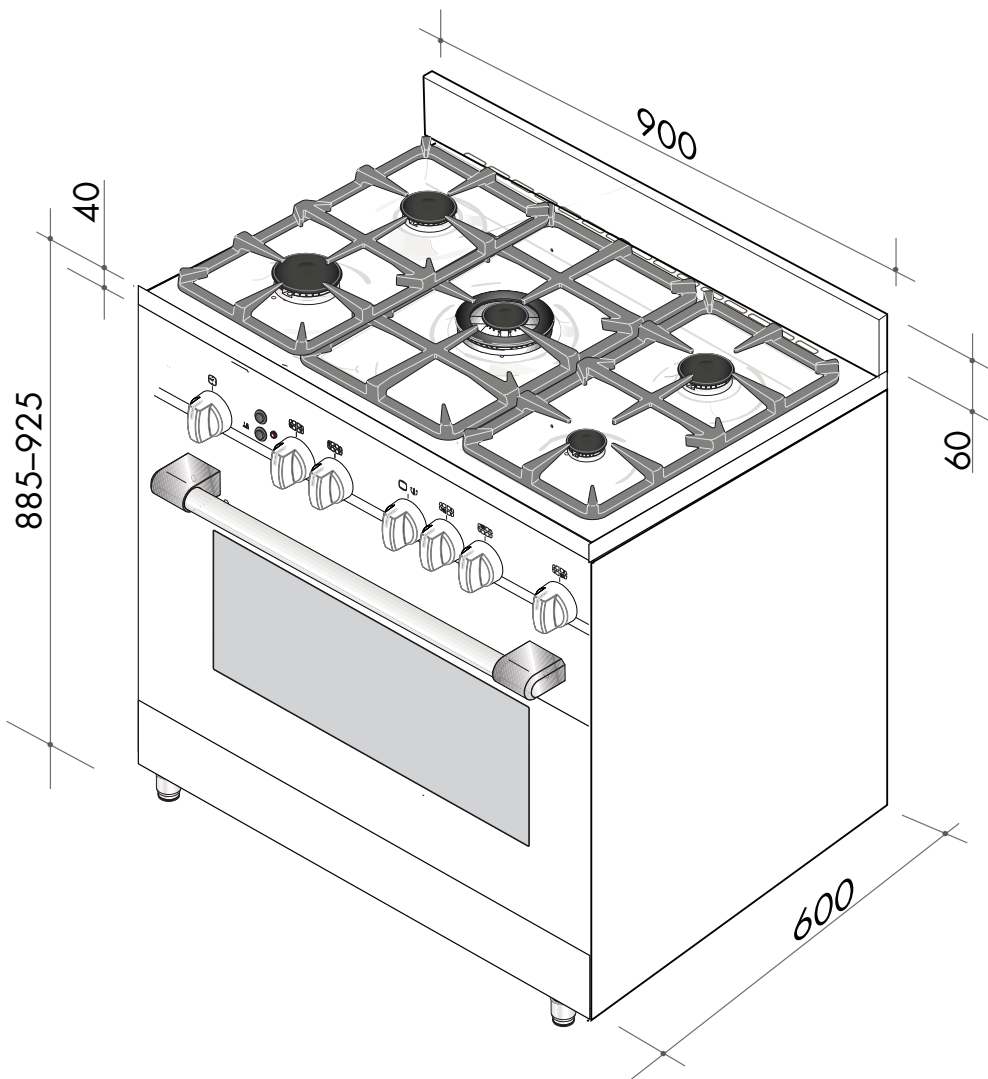

NB: drawings are not to scale — they are to be used as a guide only

Australia National Telephone Number 1300 694 583 New Zealand Telephone Number 0508 458 369
ARTUSI showrooms are open daily from 9am-5pm and Saturdays 10am-4pm

artusi.com.au

NSW & ACT
(head office)

48 Moore Street
Leichhardt
02 8569 4699

VIC | SA

1211 Toorak Road
CAMBERWELL
03 9809 2155

TASMANIA

3 Pear Avenue
DERWENT PARK 7009
03 6272 7386

QLD

1/42 Cavendish Road
COORPAROO
07 3397 0850

WA | NT

10/55 Howe Street
OSBORNE PARK
08 9201 9188

New Zealand

PO Box 11.160
Sockburn Christchurch
03 344 5913